

**SETUP SHEET**

NAME \_\_\_\_\_  
 COUNTRY \_\_\_\_\_  
 RACE \_\_\_\_\_  
 TRACK \_\_\_\_\_

DATE \_\_\_\_\_ TEMP. °C AIR / TRACK \_\_\_\_\_ / \_\_\_\_\_  
 TRACK CONDITION TECHNICAL  CARPET  ASPHALT   
 MIXED  FAST   
 TRACTION LOW  MEDIUM  HIGH

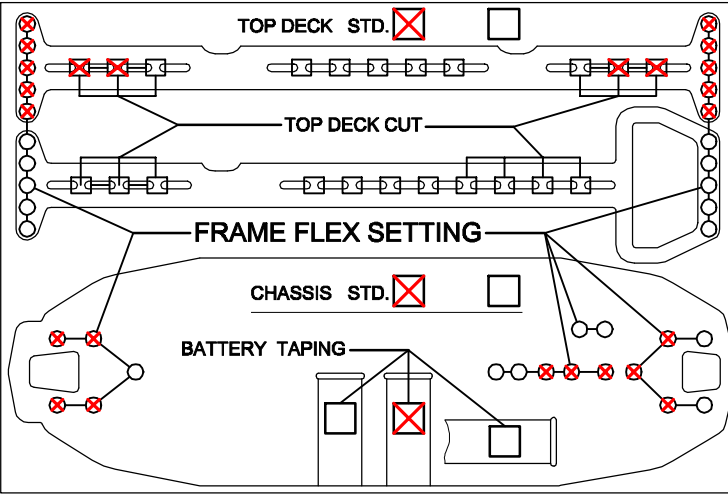

MOTOR LAYOUT LONG.  TRANS.  MOTOR \_\_\_\_\_  
 SERVO LAYOUT LEFT  RIGHT  SERVO \_\_\_\_\_  
 ESC LAYOUT LEFT  RIGHT  ESC \_\_\_\_\_  
 BAT. LAYOUT R1  R2  F1  F2  BATTERY \_\_\_\_\_  
 SPUR \_\_\_\_\_ PINION \_\_\_\_\_ RECEIVER \_\_\_\_\_  
 MOTOR PLATE OFFSET **0** MM MOTOR OFFSET **0** MM  
 BODY \_\_\_\_\_ WING \_\_\_\_\_

FL	FR	RL	RR	TIRES	FRONT	REAR
				BRAND		
				INSERTS		
				WHEELS		
				ADDITIVE		

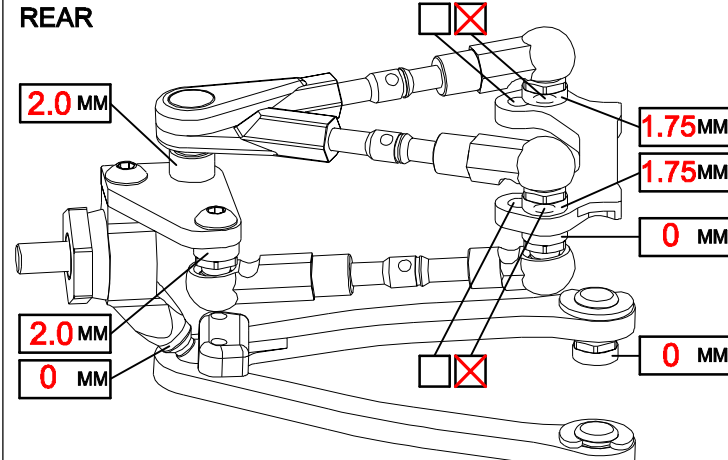
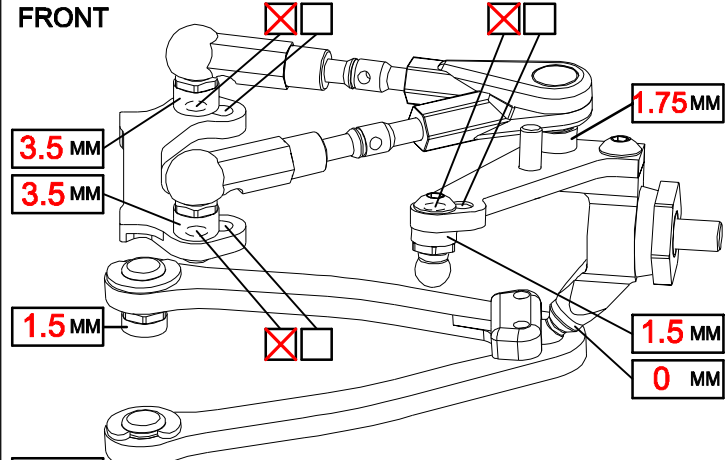

SHOCKS

SPRING STD.    
 DAMPER #1    
 ACTION SYM.  ASYM.   
 A SETTING **5.0** MM  
 B SETTING **3.0** MM

SHOCKS

SPRING STD.    
 DAMPER #1    
 ACTION SYM.  ASYM.   
 A SETTING **5.0** MM  
 B SETTING **3.0** MM

RIDE HIGH <b>5.0</b> MM	DROP <b>1.5</b> MM
CAMBER <b>1.0</b> DEG	CASTOR <b>5.0</b> DEG
TOE <b>0</b> DEG	UPSTOP <b>1.0</b> MM
STABILIZER Ø <b>1.4</b> MM	WHEEL SPACER <b>0.5</b> MM
LOW SUSP. ARM <b>STD</b>	UPPER ARM HOLDER <b>STD</b>

FRONT DRIVE SPOOL  ONE-WAY  DIFF / OIL  **30000** CST  
 DIFF. TENSION / TYPE LOOSE  MEDIUM  TIGHT  GEAR   
 DOGBONE DRIVE BB  C-DRIVE  BUSHING  EVD

RIDE HIGH <b>5.5</b> MM	DROP <b>2.0</b> MM
CAMBER <b>1.5</b> DEG	CASTOR <b>0</b> DEG
TOE-IN <b>2.5</b> DEG	UPSTOP <b>1.0</b> MM
STABILIZER Ø <b>1.2</b> MM	WHEEL SPACER <b>0.5</b> MM
LOW SUSP. ARM <b>STD</b>	UPPER ARM HOLDER <b>STD</b>

REAR DRIVE DIFFERENTIAL OIL **1000** CST  
 DIFF. TENSION / TYPE LOOSE  MEDIUM  TIGHT  GEAR   
 DOGBONE DRIVE BB  C-DRIVE  BUSHING  EVD

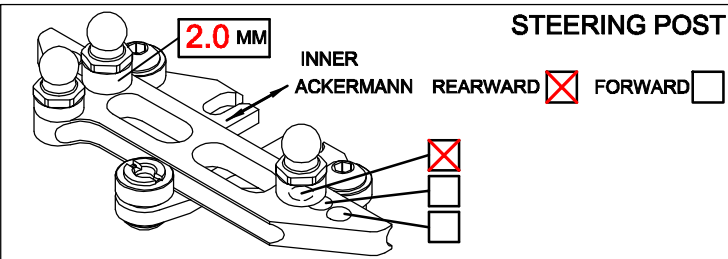

BEST LAPTIME \_\_\_\_\_ QUALIF. / FINAL POSITION **1 / 1**  
 ESC SETTING \_\_\_\_\_  
 COMMENTS / IMPRESSIONS *AWESOME !!!*  
 \_\_\_\_\_  
 \_\_\_\_\_  
 CONTACT \_\_\_\_\_